

**RoMan<sup>®</sup>**

**MANUFACTURING**

*"THE POWER TO TRANSFORM"*

**UNIVERSAL PRODUCT MANUAL**

## INTRODUCTION

This manual Provides general guidance for the RoMan Manufacturing Inc. (hereafter referred to as RoMan throughout this guide) products. This document will cover RoMan’s general guide to troubleshooting, maintenance, and the basic standards that RoMan follows. Additionally, all safety precautions listed in this document must be supplemental to all local laws and standards.

For more information, please refer to the specific documentation for your product model, or other RoMan publications pertaining to your specific product.

## TABLE OF CONTENTS

<b>INTRODUCTION .....</b>	<b>2</b>
<b>TABLE OF CONTENTS .....</b>	<b>2</b>
<b>SAFETY .....</b>	<b>4</b>
<b>HAZARD IDENTIFICATION .....</b>	<b>4</b>
<b>ARC FLASH HAZARD .....</b>	<b>4</b>
<b>INTENDED USE .....</b>	<b>6</b>
<b>INSTALLATION .....</b>	<b>7</b>
<b>UNPACKING .....</b>	<b>7</b>
<b>INSTALLATION .....</b>	<b>9</b>
<b>OPERATION .....</b>	<b>11</b>
<b>COMMISSIONING.....</b>	<b>11</b>
<b>OPERATIONAL SAFETY.....</b>	<b>12</b>
<b>MAINTENANCE .....</b>	<b>13</b>
<b>SUGGESTED MAINTENANCE .....</b>	<b>13</b>
<b>DISPOSAL.....</b>	<b>13</b>
<b>TROUBLESHOOTING.....</b>	<b>14</b>
<b>APPENDIX A: BOLTS, WASHERS, AND TORQUES.....</b>	<b>17</b>
<b>APPENDIX B: REFERENCED DOCUMENTS .....</b>	<b>18</b>
<b>ROMAN DOCUMENTS .....</b>	<b>18</b>
<b>PUBLISHED STANDARDS.....</b>	<b>18</b>
<b>ROMAN TOLERANCE STANDARDS.....</b>	<b>18</b>
<b>APPENDIX C: WATER QUALITY STANDARDS.....</b>	<b>19</b>
<b>APPENDIX D: LONG TERM STORAGE STARTUP PROCEDURE .....</b>	<b>20</b>
<b>APPENDIX E: NEMA AND IP RATINGS .....</b>	<b>21</b>
<b>BACKGROUND .....</b>	<b>21</b>
<b>GENERAL RATINGS.....</b>	<b>21</b>
<b>ROMAN GENERAL STANDARDS.....</b>	<b>21</b>
<b>APPENDIX F: TAP SWITCH MANUAL .....</b>	<b>22</b>

INSTALLATION .....	22
SERVICE & MAINTENANCE.....	23
APPENDIX G: WELDING ADDENDUM.....	24
BACKGROUND .....	24
APPENDIX G: WELDING ADDENDUM.....	24
BACKGROUND .....	24
APPENDIX H: MAXIMUM CURRENT THERMAL CALCULATIONS.....	27
RECTIFIER DUTY CYCLE CALCULATION.....	27
TRANSFORMER DUTY CYCLE CALCULATION .....	27
AC TRANSFORMERS: .....	29
SECONDARY LOAD CHART GUIDE .....	30
SECONDARY GROUNDING GUIDE.....	31
APPENDIX I: FURNACE ADDENDUM.....	33
LOAD POWER RATING.....	33
AC TRANSFORMER POWER RATING .....	34
3 PHASE POWER.....	35
IGBT CONTROL TECHNOLOGY.....	36
APPENDIX J: MONITORING.....	37
THERMAL MONITORING .....	37
FLOW MONITORING .....	38
TERMINAL LABELS .....	39
NOTES .....	39

---



## SAFETY

---

Prior to installation, commissioning, operation, maintenance, or decommissioning of the product, it is recommended that a risk assessment be conducted to identify how the product is to be used, maintained, and operated.

Always review all tags and instructions provided to ensure safer operation of RoMan products.

### HAZARD IDENTIFICATION

	<b>Danger:</b> Indicates an imminently hazardous situation that, if not avoided, will result in death or serious injury. This signal word is to be limited to the most extreme situations.
	<b>Warning:</b> Indicates a potentially hazardous situation that, if not avoided, could result in death or serious injury.
	<b>Caution:</b> Indicates a potentially hazardous situation that, if not avoided, may result in minor or moderate injury. It may also be used to alert against unsafe practices.

The product is supplied with various hazard warning labels that are designed to ANSI Z535.4 requirements. All hazard labels indicate the hazard, the severity of the hazard, and methods of avoiding interaction with the hazard within the product.

### ARC FLASH HAZARD

NFPA 70E, Article 110.16 requires that an arc flash label be affixed to the product to warn Qualified Personnel of the potential arc flash hazards. The arc flash label shall comply with the requirements of NFPA 70E.

When installing a RoMan product, the product must be installed by qualified personnel in accordance with International, National, and Local codes for electrical installations.

#### **CODES**

UL 508A provides guidance on properly enclosing products.

NFPA-70E Provides guidance for safe installation and practices.

IEC 61482 provides guidance for personal protection in accordance with IEC standards.

NOTE: these are not all the applicable standards that may apply. It is the responsibility of the end user to ensure safe conditions before operating the product.

#### **ARC FLASH PREVENTION**

The incoming power side of the product, also called the primary side, as well as the output power side, also called the secondary side, must be installed such that arc flash will not contact personnel.

This may be accomplished via enclosing the product within suitable containment, or by providing an arc flash safe distance perimeter.

## LABELING

Product will be labeled with one of several types of hazard labels as applicable. Two variations are displayed below.



### Danger/Shock and Arc Flash

Word Message: Shock and arc flash explosion hazards. Follow ALL requirements in NFPA 70E for safe work practices and for personal protective equipment (PPE). Hazardous voltage. Contact may cause electric shock or burn. Turn off and lock out system power before servicing.



### Danger/Shock & Arc Flash

Word Message: Shock and arc flash hazards. This equipment poses shock and arc flash hazards that, if occur, will cause severe injury or death. Only qualified personnel should open or work on this equipment. Wear proper protective equipment before opening or performing diagnostic measurements or testing while energized (see NFPA 70E)

## VOLTAGE RATING

Refer to the nameplate for appropriate values for application of applicable standards.

NOTE: Units rated under 50 volts may still produce currents that may melt current carrying material. Appropriate precautions should be taken to prevent arc flash and the melting of conducting material.

## ARC FLASH VOID OF WARRANTY

Failure to comply with required arc flash hazard prevention measures will void all warranties and remove RoMan's responsibility for any damages or personal injury.

## **INTENDED USE**

### **QUALIFIED PERSONNEL**

Persons qualified to use this manual and interact with RoMan products must have formal training in the installation and/or use of industrial products and industrial environments. Formal training such as OSHA10 (or OSHA30 preferred), Electrical Safety and Electrical Installation, Hydraulic Systems, Thermal Systems, and general mechanical assembly are required to properly install service and maintain this product. Any persons interacting with our product must not be under the influence of alcohol, drugs, or other medication that may influence their responsiveness.

### **INAPPROPRIATE USE**

Any use other than that described as the intended use is considered inappropriate use and is inadmissible. RoMan does not assume any liability for damage caused by inappropriate use. The risks resulting from inappropriate use are to be assumed by the operator/user alone.

---

## INSTALLATION

---

The product installer (Qualified Personnel) should perform the following steps to ensure a safe and quality installation. Please read this manual before starting the installation of the product.

These instructions do not replace national or local electrical codes. Check all applicable electrical codes to ensure compliance.

Installation of the product should only be performed by Qualified Personnel.

### UNPACKING

#### **UNPACKING AND PRELIMINARY INSPECTION**

Inspect the shipping crate(s) for damage or signs of mishandling before unpacking the product.

Remove any securing bands and cardboard packing materials and inspect the product for any obvious shipping damages. If any damage due to shipping is observed, immediately file a claim with the shipping agency and forward a copy to RoMan.

#### **HANDLING CONSIDERATIONS**

Products come in various shapes and sizes. Check the size and weight of the product, as well as the proper lifting points as found in your specific product documentation, before attempting to lift with a forklift or pallet jack.

If the product is going to be lifted using an overhead crane, it is recommended that a lift plan be developed prior to movement.

#### **STORAGE**

The product should be stored in a clean, dry environment. Storage temperature range is -10 °C to 65 °C. Care should be taken to avoid condensation. All packing and shipping materials should be left intact until the product is ready for final installation. If the product has been stored for an extended period of time, it should be wiped down with a damp cloth and carefully inspected before placing into service.



In the case that the product is being stored after it has already been in service, ensure that water passages are clear and dried. If water remains within the cooling circuit, it may freeze in storage and cause damage. This may be accomplished by blowing out passages with clean dry air.

#### **ENVIRONMENT**

RoMan product is designed for operation indoors in ambient temperatures of 10°C to +50°C with a relative humidity of 0% to 95% (non-condensing) as a standard. Other ratings may exist per user agreement.

## SERVICE CLEARANCES

Service clearances are needed for all products to allow maintenance to be completed safely. The clearance distances must also consider the maximum voltage capability. The clearance distances recommended are detailed in applicable safety standards such as NFPA 70 or others as defined by governing codes at the site of installation.

## MOUNTING



Refer to associated drawings for mounting dimensions.



Electrical connection pads are not intended to be load-bearing. Applying physical load to an electrical pad may cause coolant leaking or malfunction of the product's operation over time.

## LABELING

All RoMan products have a label containing all the basic characteristics of the product. As seen below, the label includes everything from the customer product order number to the serial number of the specific product. It may also give information such as turns ratios for each tap. This is the best resource to double check the rated kVA and Duty Cycle, the required water flow rate, and the turns ratio of the tap that you are using or want to use.

<b>RoMan</b>		 <small>QMS Certified to ISO 9001</small> 
<b>MANUFACTURING</b> <small>Grand Rapids, MI (616) 530-8641</small>		
<b>CUST PO#:</b>		
<b>MODEL#:</b>		
<b>CUST. MODEL#:</b>		
<b>SPEC#:</b>		<b>SO#:</b>
<b>KVA:</b>	<b>AT</b>	<b>DUTY CYCLE</b>
<b>WATERFLOW:</b>	<b>GPM</b>	
<b>155 DEGREE C INSULATION</b>		
<b>PRI.VOLT.:</b>		
<b>FREQUENCY:</b>	<b>(Hz)</b>	<b>PHASE</b>
<b>SEC. V. MIN.:</b>	<b>SEC. V. MAX.:</b>	
<b>SERIAL #:</b>	<b>DATE:</b>	
<b>LO Volt. Turns Ratio</b>	<b>HI Volt. Turns Ratio</b>	
<b>TAP 1</b>	<b>TAP 1</b>	
<b>TAP 2</b>	<b>TAP 2</b>	
<b>TAP 3</b>	<b>TAP 3</b>	
<b>TAP 4</b>	<b>TAP 4</b>	
<b>TAP 5</b>	<b>TAP 5</b>	
<b>TAP 6</b>	<b>TAP 6</b>	
<b>TAP 7</b>	<b>TAP 7</b>	
<b>TAP 8</b>	<b>TAP 8</b>	



## **INSTALLATION**



Prior to installation, all energy sources (electrical, air, vacuum, water, etc.) shall be locked and tagged in accordance with OSHA 29 CFR 1910.147.

**NOTE:** Installation of the product should only be performed by Qualified Personnel.

### **SYSTEM EARTHING (GROUNDING) & BONDING**

The performance and safe operation of the product is dependent on proper earthing (grounding) and bonding. Earthing (grounding) is required primarily for safety. All electrical circuits to the product should include an earthing (grounding) conductor as required by the NFPA 70 or ANSI Z49.1 and local codes. If the secondary is to be grounded, it is suggested that the negative pad is grounded.



To prevent circulating currents and nuisance shock, ensure that the power circuit is not grounded more than once.

### **ELECTRICAL INSTALLATION**

Ensure all fittings are appropriate for the size, material, and type of conduit or cable tray. It is recommended by RoMan that on all bolted joints, a flat washer is used on each side and a Bellville washer on the nut side.

Ensure that the electrical source provided to the product has the correct voltage, number of phases, and ampacity.

### **PROCESS POWER**

All input conductors shall be equipped with a lockable disconnecting means that complies with the lockout tagout (LOTO) requirements in OSHA 29 CFR 1910.147.

Route input conductors to an over-current protection device. The range of conductor sizes is noted in the accompanying schematics or drawings. All conductors shall comply with bend radius requirements detailed in NFPA 70.

Install Phase A (Line 1), Phase B (Line 2), Phase C (Line 3), Neutral, and Ground conductors into the main circuit breaker (as appropriate). Do not trim the number of conductor strands as this can reduce the ampacity of the conductor.

Ensure all installed conductors are tightened per torque specifications detailed on the circuit breaker. Route output conductors to the output terminal blocks or bus bars. The range of conductor sizes is noted in the accompanying schematics or drawings.

### **WATER INSTALLATION**

All input hoses shall be equipped with a lockable disconnecting means that complies with the lockout tagout (LOTO) requirements in OSHA 29 CFR 1910.147.

Install input/output water hose lines to the connections noted on the product schematics or drawings.

Use hydraulic sealant such as Permabond LM012 or other approved sealing medium on pipe fittings and ensure that there are no leaks in the circuit.

Ensure that coolant flow and quality requirements are met as noted in RWMA Bulletin 14 (See Appendix C) and your specific product documentation.

RoMan recommends that water is filtered to a maximum particle size of 50 microns. This value is required by many flow control products for trouble-free operation. Failure to meet flow control's requirements would void warranties on those components. Although this would not void RoMan warranty it is unlikely operation would be possible without the peripheral components and the water quality requirements dictate relatively small particle sizes are required to meet and maintain water quality requirements.

## OPERATION

---

### COMMISSIONING



Prior to applying electrical power, be sure to review and adhere to safety labeling applied to the product.

The order of commissioning is important to the overall safety, reliability, and performance of the product.

NOTE: Before commissioning any products that have been stored for an extended period of time, please see Appendix D.

#### **WATER COMMISSIONING**

1. Remove lockout tagout locks from the water source.
2. Activate water source allowing water to flow through the product.
3. Inspect product for leaks visually.
4. After Electrical commissioning, verify inlet temperature is at or below 30° C (refer to labelling to verify inlet temperature rating) and ensure outlet temperature is at or below 60° C.

#### **ELECTRICAL POWER COMMISSIONING**

1. Ensure all circuit breakers and switches are in the OFF position.
2. Place all tap switches on the lowest output voltage setting for startup; the switch can later be set to the anticipated load.
3. Remove lockout tagout locks from the power source.
4. Measure the voltage at the Process Power main circuit breaker.
5. If the voltage at the Process Power main circuit breaker is within tolerance (+/- 10% of nominal for utility feeds), compared to rated values noted on the product schematics or drawings, energize sub-circuits individually (as appropriate).
6. Measure the voltage at the Process Power output terminal or the load (as appropriate) and increase slowly to desired output value ensuring that rated power does not exceed design power rating and all peripherals are operating within expected values.

## OPERATIONAL SAFETY



During regular operation of electrical products, there are strong magnetic fields present. This may affect the function of cardiac pacemakers, various implants, hearing aids, and other electronics.



Hazardous voltage is present during operation. Use proper lockout tagout (LOTO) procedures as found in OSHA 29 CFR 1910.147 and use appropriate Personal Protective Equipment (PPE).

## MAINTENANCE

---



Hazardous voltage present. Use proper lockout tagout (LOTO) procedure and use appropriate Personal Protective Equipment (PPE). Before performing any maintenance, shut down all power to the system and be sure that all voltages have been reduced to harmless levels.

### SUGGESTED MAINTENANCE

According to RWMA Bulletin 14, maintenance should be performed as follows:

#### **MONTHLY PERIODIC INSPECTION AND SERVICE**

- Check for water flow.
- Check for water leaks; repair if necessary.
- Check secondary connections and ensure they are secure.
- Check water hoses for deterioration.
- Check for loose or broken components.
- Ensure secure mounting.

#### **QUARTERLY MAINTENANCE**

- Thoroughly check the water system and replace worn or corroded components.
- Remove any grease, rust, corrosion, or welding flash from all secondary contact surfaces using a fine grade scouring pad.
- Tighten all connections to the proper torque specifications.
- Ensure functionality of all protective devices

#### **ANNUAL MAINTENANCE**

- Remove all grease and rust from the product.
- Check all electrical connections for secure connections.
- Reverse-flush the cooling system and replace any hoses as necessary.

### DISPOSAL

If you have a product that you believe is no longer usable or one you do not have any use for, contact RoMan. Our service and repair department will evaluate it for refurbishment or offer to responsibly recycle and dispose of the product free of charge in compliance with ISO 14001-2004 to prevent pollution.

## TROUBLESHOOTING

SYMPTOMS	CHECKPOINTS	SOLUTION
Product will not turn on	Ensure that primary cables are properly connected	Connect the primary power to the product
	Ensure breakers are turned on	Put breakers in the on position
	Ensure the control is receiving power	Connect the proper power input to the control and turn on the proper breakers
Product is overheating	Ensure the total load is within the product's kVA rating	Reduce load or replace with a larger product
	Ensure there is no discoloration in the cables due to heating	Cable connections should be cleaned and tightened per maintenance schedule
	Ensure the product is operating within the rated current range and rated duty cycle.	Adjust the duty cycle of the product to be at or below the rated duty cycle found in your product documentation
	Ensure water flow and quality are within specifications	Ensure the proper amount of water is flowing through the product per the physical drawing by using an external flow meter on the output of the water circuit
		Blow out the water lines with compressed air to remove water and any debris
	Ensure all temperature sensing connections are transmitting the proper signal	Verify the temperature measurement circuit is working properly
Secondary voltage is too high	Ensure that the product is wired correctly per the input voltage	Verify the product being installed is the correct voltage for the application
	Confirm turns ratio	Verify that the taps are set correctly
		Verify that conductors are connected per the physical drawing

<b>SYMPTOMS</b>	<b>CHECKPOINTS</b>	<b>SOLUTION</b>
Secondary voltage is too low	Ensure the product is wired correctly per the input voltage	Verify the product being installed is the correct voltage for the application
	Ensure all connection points are tightened per the torque chart in Appendix A, smooth, and cleaned of any insulation, corrosion, or debris	Replace any damaged cables or connections. Verify any mechanical components are tight
	Ensure the turns ratio is as expected in comparison to product documentation	Verify that the taps are set correctly
		Verify that conductors are connected per the physical drawing
	Ensure primary and secondary conductors are appropriate for the load	Replace conductors as necessary to properly accommodate the desired output
Reduced Secondary Current	Ensure that proper grounding protocol is adhered to	Comply with a proper grounding scheme
	Ensure the secondary is not shunted and does not have an increased secondary impedance	Ensure the load is within the rated capacity of the product
	Ensure the correct turns ratio is programmed into the control	Confirm the turns ratio of the product, and reprogram the correct turns ratio into the control
	Ensure primary and secondary conductors are appropriate for the load	Replace conductors as necessary to properly accommodate the desired output

SYMPTOMS	CHECKPOINTS	SOLUTION
Loss of secondary current	Ensure all connection points are tightened per the torque chart in Appendix A, smooth, and cleaned of any insulation, corrosion, or debris	Ensure secure bolted connections
	Ensure the secondary pads are not supporting a physical load	Remove physical load from secondary pads, or support the load externally
	Ensure circuit breakers are working properly and are not tripped	Turn on all circuit breakers to allow operation
	Ensure all electrical joints are clear of any buildup or debris that may insulate the connection	Clear all joints of buildup that may insulate the conductors
	Ensure adequate primary current	Ensure primary current is being properly delivered to the product
Temperature of outgoing water and secondary terminals are high (>60°C)	Ensure adequate water flow and appropriate water temperature	Ensure water flow and temperature is in compliance with water commissioning values
Condensation on product secondary components on humid days	Ensure the insulation is adequately insulating components	Shut off water when product not in use
	Ensure water temperature is above the dew point	Heat the water as necessary to remain above the dew point
Fluids on product	Ensure all bolted joints are secure	Torque all bolted joints as listed in Appendix A
	Ensure the secondary pads are not supporting a physical load	Remove physical load from secondary pads, or support the load externally
	Ensure all "O" ring connections are properly sealed	Replace "O" rings as necessary



## APPENDIX A: BOLTS, WASHERS, AND TORQUES

RoMan recommends lightly lubricated connections. This chart is defined as a RoMan Standard and is a compilation of research on bolt torque science which varies among manufacturers. Alternate values can be applied but RoMan cannot assume any responsibility for damage as a result torquing to a specific manufacturers recommendation.

Diameter (in)	Diameter (mm)	Engagement	Hardware Material Type	Suggested Torque (ft.lbs.)
1/4-20	M6	Threaded Hole	Grade 5	72 in.lbs.
			Stainless Steel	
		Through Hole	Grade 5	96 in.lbs.
			Stainless Steel	72 in.lbs.
5/16-18	M8	Threaded Hole	Grade 5	11
			Stainless Steel	
		Through Hole	Grade 5	17
			Stainless Steel	11
3/8-16	M10	Threaded Hole	Grade 5	20
			Stainless Steel	
		Through Hole	Grade 5	30
			Stainless Steel	20
1/2-13	M12	Threaded Hole	Grade 5	43
			Stainless Steel	
		Through Hole	Grade 5	75
			Stainless Steel	43
5/8-11	M16	Threaded Hole	Grade 5	75
			Stainless Steel	
		Through Hole	Grade 5	140
			Stainless Steel	92

If not covered by this chart, please refer to the manufacturer's recommendations.

- Electrical connections should have a pair of Belleville Spring washers.
- Non-electrical mechanical connections should use Belleville washers, lock washers or an equivalent method, i.e. Vibratite.
- Robifix Pins should be torqued to 40 inch - pounds per the manufacturer's recommendation.
- Riv-Nuts and helicoils are torqued to threaded hole values.
- Review RoMan product sheets for any specifically defined torque values.

## **APPENDIX B: REFERENCED DOCUMENTS**

---

### **ROMAN DOCUMENTS**

- Your Specific Product Documentation
- Troubleshooting Guide
- RoMan Grounding and Secondary Current Guide
- RoMan Tap Switch Manual

### **PUBLISHED STANDARDS**

- NFPA 70
- NFPA 70E
- NFPA 70E Article 110.16
- ANSI Z535.4
- OSHA 29 CFR 1910.147
- ISO 14001-2004
- AWS J1.2M/J1.2:2016
- UL 508A
- IEC 61482

### **ROMAN TOLERANCE STANDARDS**

- Output Pad Surface finish: RoMan products are manufactured to have a surface finish minimum of Ra of 1.60 $\mu$ m (63 $\mu$ in.) with typical values between 1.06 (42 $\mu$ in.) and 0.38 (15.0 $\mu$ in.).
- Input Pad Surface finish: Input Bar connections are mill produced extrusion or plate values which typically fall within the RoMan standard for output pads (Variations may occur).
- Maintaining electrical contact Surface finish: Surfaces which have light imperfections or corrosion may be buffed with a cotton polishing wheel or a non-material removing scotch bright pad. Alternatively, an experienced machinist may lightly stone a surface with an appropriate stone for creating an Ra of 1.06 or better.
- Mounting Surface finish: There are a variety of surface finishes related to mounting. For mounting areas that are machined and Ra of 1.6 or better will be typical (variations may occur) for other surfaces such as angle iron. sand casted surfaces, painted surfaces the surface may have a typical Ra value of 6.30 $\mu$ m (250 $\mu$ in.)
- Dimensional Tolerances: All RoMan produced product is measured per mechanical drawings with stated tolerance blocks (please consult factory in event a tolerance block is omitted).
- Electrical Tolerances: All RoMan produced product is measured per calculated electrical test documents. Values are recorded and test data sheets are available upon request.

## APPENDIX C: WATER QUALITY STANDARDS

---

As written in RWMA Bulletin 14

### Water Quality

The cooling water should have the following qualities:

1. pH between 7.0 and 9.0
2. Maximum Chloride content of 20 PPM
3. Maximum Nitrate content of 10 PPM
4. Maximum Sulphate content of 100 PPM
5. Maximum Solids content of 250 PPM
6. Maximum Calcium Carbonate content of 250 PPM
7. Resistivity greater than 2,000 ohm-cm at 77 °F (25°C).

Deionized water should not be used in a closed water system unless the water is constantly recirculated through the deionizer. Deionized water is ion-hungry and still contains many water-soluble gases which will quickly reduce the resistivity of the water if not continually run through the deionizer.

Water quality may vary from location to location. RoMan recommends consulting with water quality experts to determine the best practice for water filtration and chemical balance to achieve the above stated values. These may include various strainers and chemical additives. It is incumbent on the end user to ensure that any chemicals added to water do not react with Copper, Brass, Stainless Steel (type 304 and 316), various natural and synthetic rubbers such as silicone and SBR (Styrene-Butadiene Rubber), Teflon, Methacrylate esters Pipe thread sealants), Silver and silver bearing brazes. There may be additional materials considerations based on accessories such as flow monitors and switches. Consult factory for additional information when chemicals are added.

## **APPENDIX D: LONG TERM STORAGE STARTUP PROCEDURE**

In the case of backup products, or any other situation where a product is stored for an extended period of time, some precautions should be taken to ensure safe and lasting operation of the product.

Any time a product is being commissioned after an extended period of storage, please follow the extra procedures below, in addition to all other commissioning procedures listed elsewhere in this manual.

- Inspect for visual signs of corrosion and mechanical damage.
- Check for and remove any surface corrosion on both primary and secondary leads.
- Check mechanical connections for physical degradation.
- Perform a megger check on the primary windings to ensure insulation integrity.
- Ensure that no blockages exist in the water passages that would limit product cooling. This may be accomplished by blowing out water passages with clean dry air.
- For integrally mounted tap switches, please refer to the maintenance section of Appendix E



Do not perform a megger check on diodes. Please consult the factory.

## APPENDIX E: NEMA AND IP RATINGS

---

### BACKGROUND

Electronic devices can be classified by how well they prevent foreign objects or substances from entering. These classifications are given by IP or NEMA ratings. IP ratings are the standard in Europe while NEMA are the standard in North America. Both types of ratings can be converted to one or the other but in some cases may require more testing to accurately convert between the two.

### GENERAL RATINGS

- NEMA/IP = Open frame/IP00 This rating is for open or non-enclosed terminals. This rating is unprotected and relies on the customer to provide additional protection as required by the installer.
- NEMA1/IP20 = Enclosed with prevention of contact with energized terminals.
- NEMA3/IP54 for prevention of splashing water(rain).
- NEMA12/IP64 = Protection against contact with energized terminals and dust tight to prevent particulate contaminates.
- NEMA4/IP56 = Protection against contact with energized terminals and prevention of ingress of spraying water to energized terminals.

### ROMAN GENERAL STANDARDS

Enclosed Primary ends:

For Medium Frequency DC (MFDC) products typical construction is NEMA4/IP56. All other products are NEMA3/IP54. Open ends have energized electrical connections and must be properly enclosed per location requirements. Alternative ratings are available upon request.

Secondary ends:

For all products the typical is Open/IP00 where the secondary terminals are exposed. A sizable portion of the products produced are less than 50VAC RMS and fall within low voltage output ratings, but it is recommended that protection be provided. A typical alternative is a cage frame with GPO type insulative material to form a non-conductive barrier that can be cut to allow connection of heavy cables. Alternative ratings are available upon request.

Internal construction:

All RoMan water-cooled products are constructed with epoxy encapsulant (potting) for the electrical windings which provides an IP54 (IP56 for MFDC models) level of protection to internal components. Air cooled units are not encapsulated. While not designed for submerged operation, our products undergo meticulous procedures to enhance their IP/NEMA ratings. These include potting, the addition of a protective shell, application of sealant on joints, the use of O-rings, and strategic application of wax and Loctite on appropriate fittings. These measures are implemented by default, ensuring that our products consistently meet the highest standards of performance and reliability.

Optional protection: Consult factory for custom requirements.

## APPENDIX F: TAP SWITCH MANUAL

---

The Tap Switch Manual was released by RoMan in 2008 to convey proper installation and service practices.

### **INSTALLATION**

1. The tap switch should be removed from its shipping container and inspected for shipping damage or other possible non-conformance.
2. Rotate the handle in a clockwise direction until it stops, and the plunger pin locks into place. The handle may be difficult to rotate without the tap switch being mounted, therefore, the base should be firmly held for this operation.
3. Remove the socket head cap screw from the handle as well as the (4) Phillips round head screws from the corners of the front plate. Retain these parts for installation. Pull the Front Plate and Handle from the switch assembly. Remove the (4) spacers (nylon washers) from behind the front plate. The spacers can be discarded. (They are not used in the customer installation but are used at the factory to simulate the thickness of the customer panel).
4. Mount the front plate and handle on the front of the panel, and the switch assembly behind the panel. Install and tighten the (4) Phillips round head screws through the front plate to attach the tap switch assembly in place. Install and tighten the socket head cap screw in the handle to hold in place.
5. Rotate the handle in a counterclockwise direction. The plunger pin should snap in place for each position on the front plate and the handle should not be able to rotate unless the trigger is squeezed to withdraw the plunger pin.
6. When it is possible, extra flexible lead wire of the proper gauge should be used. All leads to the switch terminals should be supported to prevent undue mechanical loads on the switch.



ALL SOURCES OF POWER MUST BE DISCONNECTED, AND PROPER LOCKOUT TAGOUT (LOTO) PROCEDURES FOLLOWED FOR INSTALLATION AND/OR MAINTENANCE OF THE TAP SWITCH. LOCAL, STATE, AND FEDERAL SAFETY PRECAUTIONS MUST BE FOLLOWED WHEN WORKING WITH ELECTRICAL POWER PRODUCT.

## SERVICE & MAINTENANCE



THE SERVICE AND MAINTENANCE OF AN ELECTRICAL PRODUCT MUST BE PERFORMED BY TRAINED AND QUALIFIED PERSONNEL. ALL SOURCES OF POWER MUST BE DISCONNECTED, AND PROPER LOCKOUT TAGOUT (LOTO) PROCEDURES FOLLOWED FOR INSTALLATION AND/OR MAINTENANCE OF THE TAP SWITCH. LOCAL, STATE, AND FEDERAL SAFETY PRECAUTIONS MUST BE FOLLOWED WHEN WORKING WITH ELECTRICAL POWER PRODUCT.

The RoMan Type RS Rotary Tap Switch is designed, manufactured, and tested to provide long service life. Dirt, moisture, and heat are the most common causes of failure of electrical switches. Perform maintenance outlined below every 6 months, or more frequently for environments with excessive dirt, moisture, or heat. This maintenance is essential in preventing premature product failure. Failure to perform this maintenance will result in the void of any warranty.

1. Dry cleaning of the tap switch assembly using a vacuum or compressed air to remove dust, dirt, etc. To remove excessive dirt build-up, the tap switch Assembly can be washed using a solvent designed to clean electrical apparatus or a mild soap and water solution can be used as well.

**WARNING:** The tap switch assembly must be removed from the product if it is to be washed and must be thoroughly dried before installation and energizing.

2. Lubricate the contact surfaces of the terminals. RoMan recommends the use of Electrolube CG80 contact treatment grease used in the manufacturing process of the tap switch. Do not over lubricate; excess grease will cause dirt to accumulate on the tap switch assembly.

**CAUTION:** Do not use other surface preparation materials such as those designed to prevent oxidation as they are not intended to be lubricants. If the tap switch is completely disassembled, lubricate the rotor assembly where it goes through the base and where it contacts the common strap. For units equipped with Zerk grease fittings, apply one or two strokes of grease depending on the grease gun. Do not over grease. Wipe ALL excess grease away with a clean cloth.

3. Tighten all connecting hardware on the terminals and common strap.
5. Cycle the tap switch to all positions to ensure smooth operation and to spread lubrication evenly across all contact surfaces every 6 months.

**WARNING:** Failure to cycle the tap switch regularly may allow the switch to seize due to grease being expelled by the pressure needed for proper electrical contact. In the event the switch does seize, do not force it to turn. Contact RoMan for repair services.

**NOTE:** The contact pressure between the rotor blades and the terminals, as well as between the rotor and the common strap is factory adjusted. Although the contact pressures are field adjustable, the adjustment should not be required during the life of the tap switch. Increasing contact pressure will only increase the operating effort and will not affect the contact efficiency.

## APPENDIX G: WELDING ADDENDUM

---

### BACKGROUND

## APPENDIX G: WELDING ADDENDUM

---

### BACKGROUND

Mid-frequency welding uses a three-phase 50/60 Hz power input converted to a single-phase square wave operating anywhere from 100 Hz to 3000 Hz. This square wave is then rectified to a high current DC output. Figure 1 below shows a basic block diagram of the control, the inverter, and the transformer.

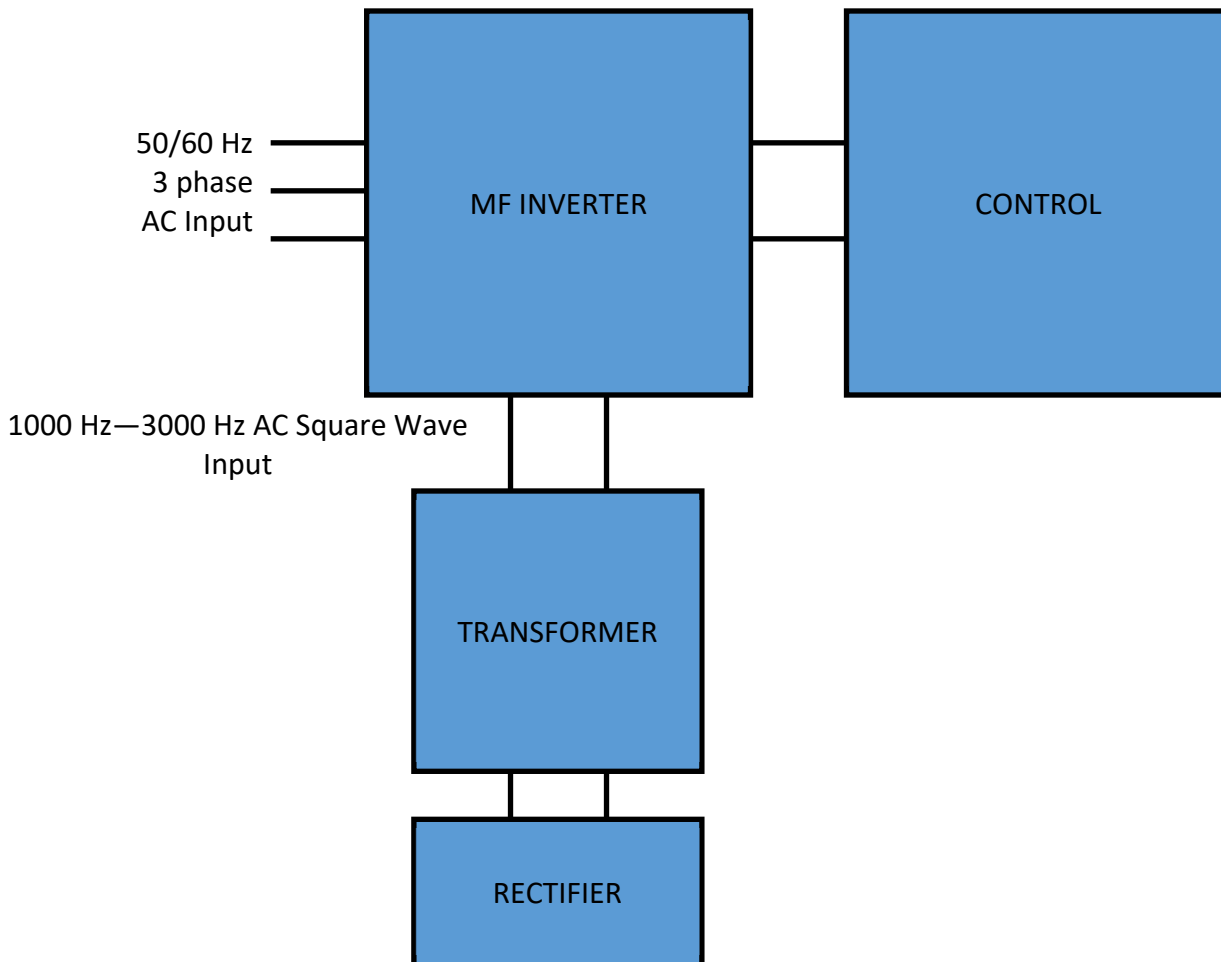

*Figure 1: Mid-frequency Inverter System, High Current DC Output*

Additionally, figure 2 shows an example of a signal that would be output from the inverter to the transformer, as well as an approximation of the resulting welding current from the output of the transformer.



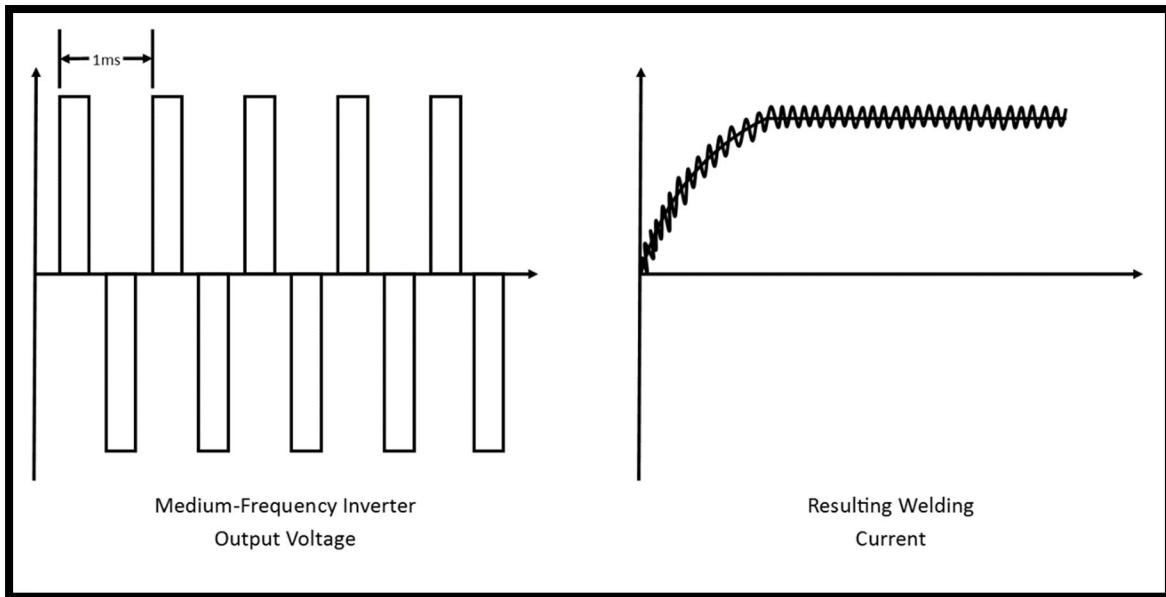

*Figure 2: Mid-frequency welding input and output signals.*

The main factor limiting the capacity of the product is the heat created within the unit. This is affected by the pulse width modulation used to control the primary input signal. As seen in figure 3, as the duty cycle of the primary voltage signal increases, it increases the overall current output of the secondary, but with that comes a higher resulting heat, which is proportional to the area under the curve, seen in yellow.

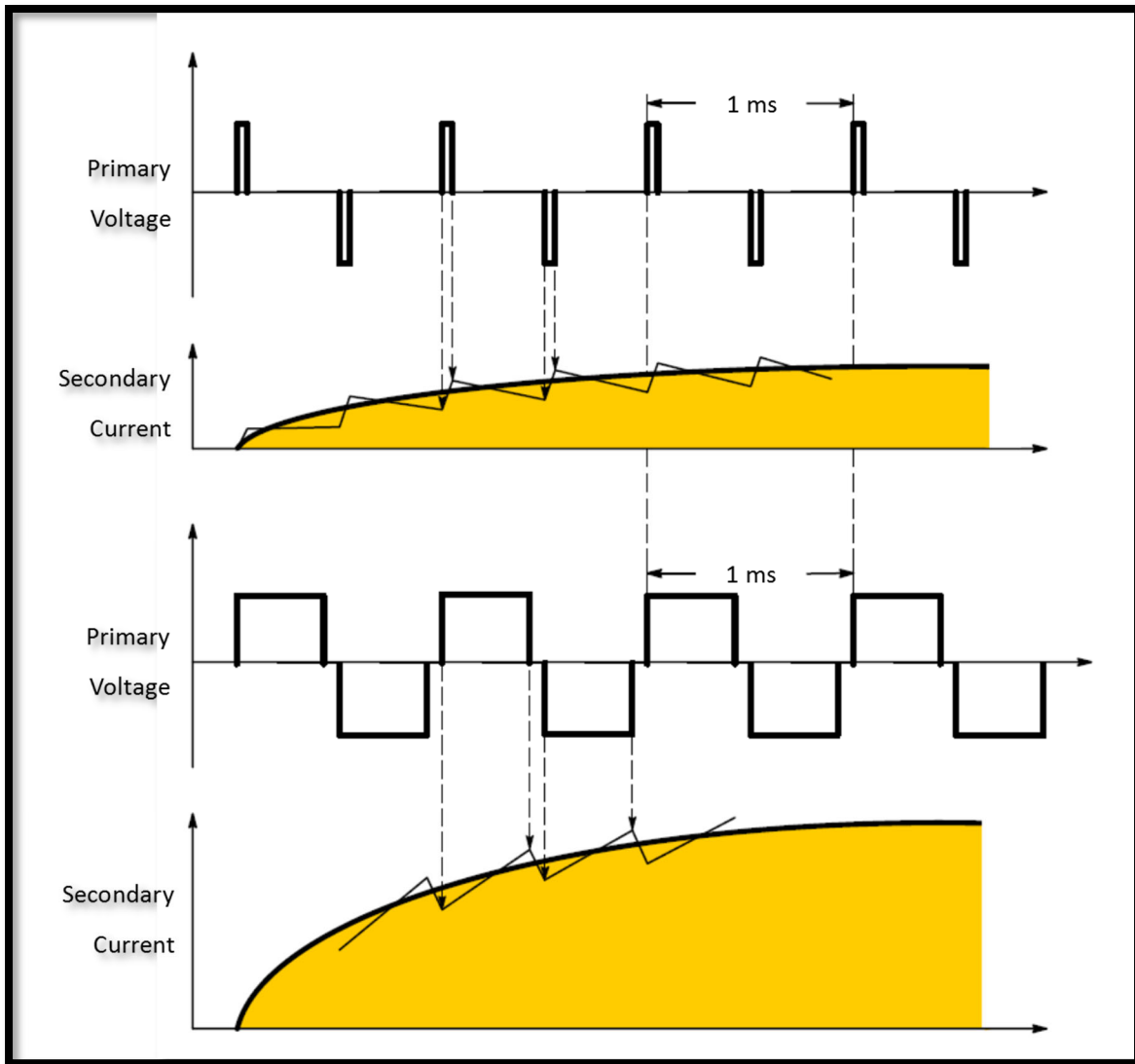

Figure 3: Resulting Heat comparison

## APPENDIX H: MAXIMUM CURRENT THERMAL CALCULATIONS

To ensure that the product is being run within recommended values, and to ensure the maintenance of the unit's warranty, the unit must be operating within an acceptable range, as seen on the diode curve in figure 6. To find the maximum current operation point, the following calculations must be made to ensure the operation is within the capability of both the windings and of the rectifier.

### RECTIFIER DUTY CYCLE CALCULATION

The rating curve in figure 6 uses the duty cycle to find the admissible current. To find the admissible current for the rectifier, use the maximum duty cycle for the specific application. For a period of 2.5 seconds, add all on time and off time and calculate the overall duty cycle as seen in the example below. If the weld times are varied, use the worst-case scenario, i.e. use the most on time the rectifier will experience within a 2.5 second period.

For example:

- Integration time 2.5 seconds
- On time: 3 welds each 200 milliseconds of on time.

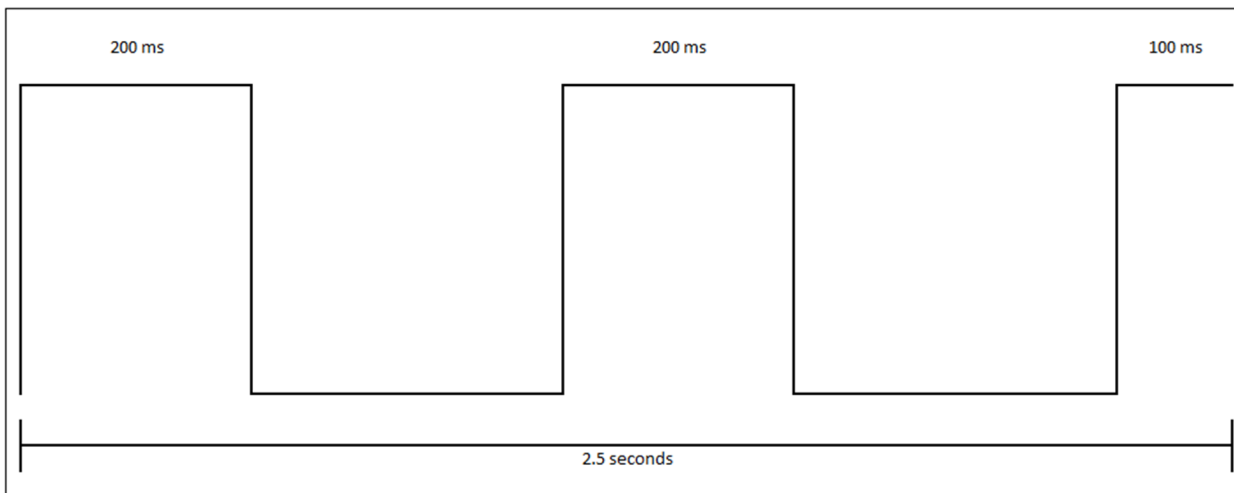

Figure 4: Rectifier

Duty Cycle Example

The Duty Cycle of the Rectifier (D.C.[Di]) is found using the following equation:

$$D.C. [Di] = \frac{\text{Weld Time}}{\text{Integration Time}} * 100\% = \frac{2 * 200 \text{ ms} + 100 \text{ ms}}{2500 \text{ ms}} * 100\% = 20\%$$

### TRANSFORMER DUTY CYCLE CALCULATION

To ensure the windings of the transformer are operating within a reasonable range, the maximum duty cycle of the transformer (D.C.[Tx]) is determined with the formula as stated below. If the application calls for a welding cycle over 1 minute, contact RoMan for assistance.

For example:

- Integration time: 60 seconds
- Number of welds: 30 welds
- On time per weld: 200 milliseconds

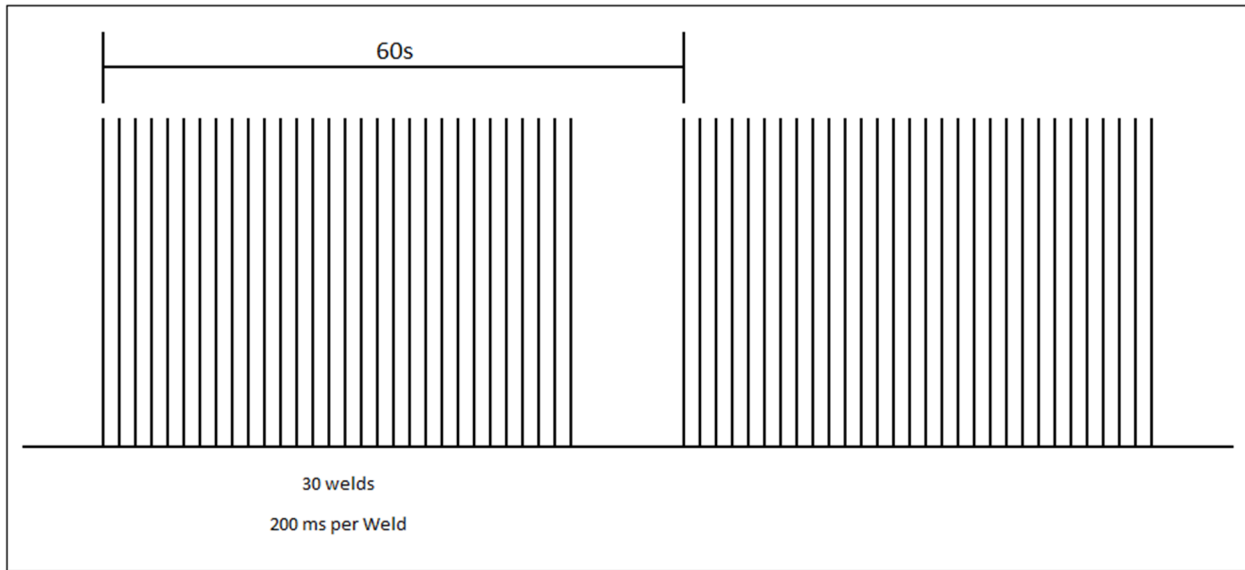

*Figure 5: Transformer Duty Cycle Example*

$$D.C. [Tx] = \frac{\text{Number of welds} * \text{time per weld}}{\text{Integration time}} * 100\% = \frac{30 * 200 \text{ ms}}{60000 \text{ ms}} * 100\% = 10\%$$

The two duty cycles calculated correspond to a range of allowable current on the rating curve. Each unit will have its own respective curve. Figure 6 displayed below is just an example of one curve.

The red curve represents the maximum admissible current based on the transformer windings at a given duty cycle. Draw a vertical line at the calculated duty cycle for the transformer, D.C.[Tx], until it intersects the red transformer curve. Next, draw a horizontal line from that intersection to find the maximum allowable current for the transformer windings. On the example rating curve, the maximum current for the windings is about 35 kA. Using the same process with the calculated rectifier duty cycle, D.C.[Di], and the 200 ms curve based on the weld time used in the duty cycle calculation, the maximum current for the rectifier is about 32 kA. For this application, the absolute maximum current is approximately 32 kA.

Note: In the case of parallel connection of products, the diode rating must be limited to an absolute maximum of 90% of the rated value. Using multiple units not matched from the manufacturer may cause premature rectifier failures and is not recommended.

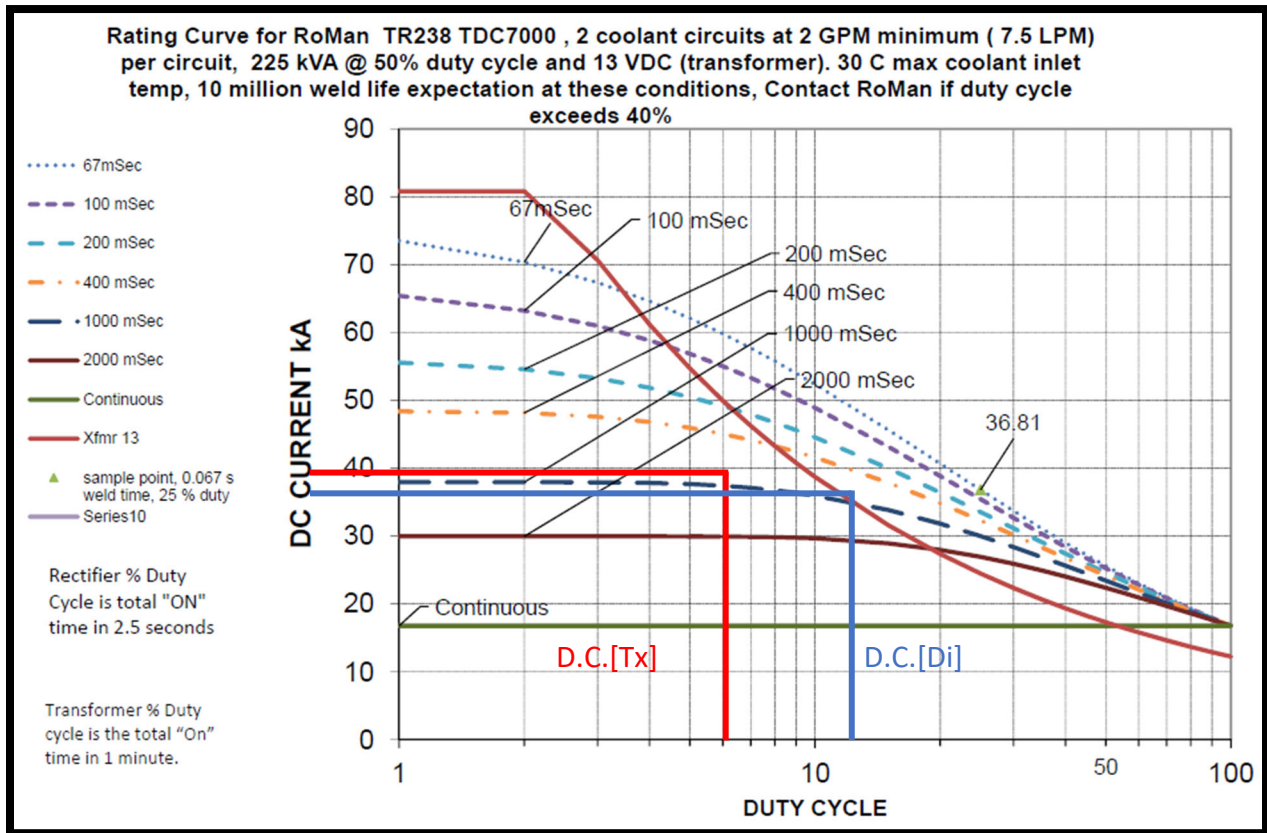

Figure 6: Rating Curve Example

### **AC TRANSFORMERS:**

In the case that the application calls for an AC transformer, there are no diodes. To ensure the application is within the allowable limit of the unit, please use the calculation for the windings alone.

## **SECONDARY LOAD CHART GUIDE**

The internal resistance of the transformer determines the maximum current output. The load resistance is defined as the electrical resistance value of all ohmic connections, line resistances, and the workpiece.

To determine the maximum current output possible at a given resistance, measure the resistance of the application's secondary circuit. As an example, say the secondary resistance is  $150\ \mu\Omega$ , draw a vertical line up from  $150\ \mu\Omega$  until it intersects with the load curve. From the point of intersection, draw a horizontal line to determine the maximum current output. In the case of the example in figure 7, the required current must be less than 46 kA.

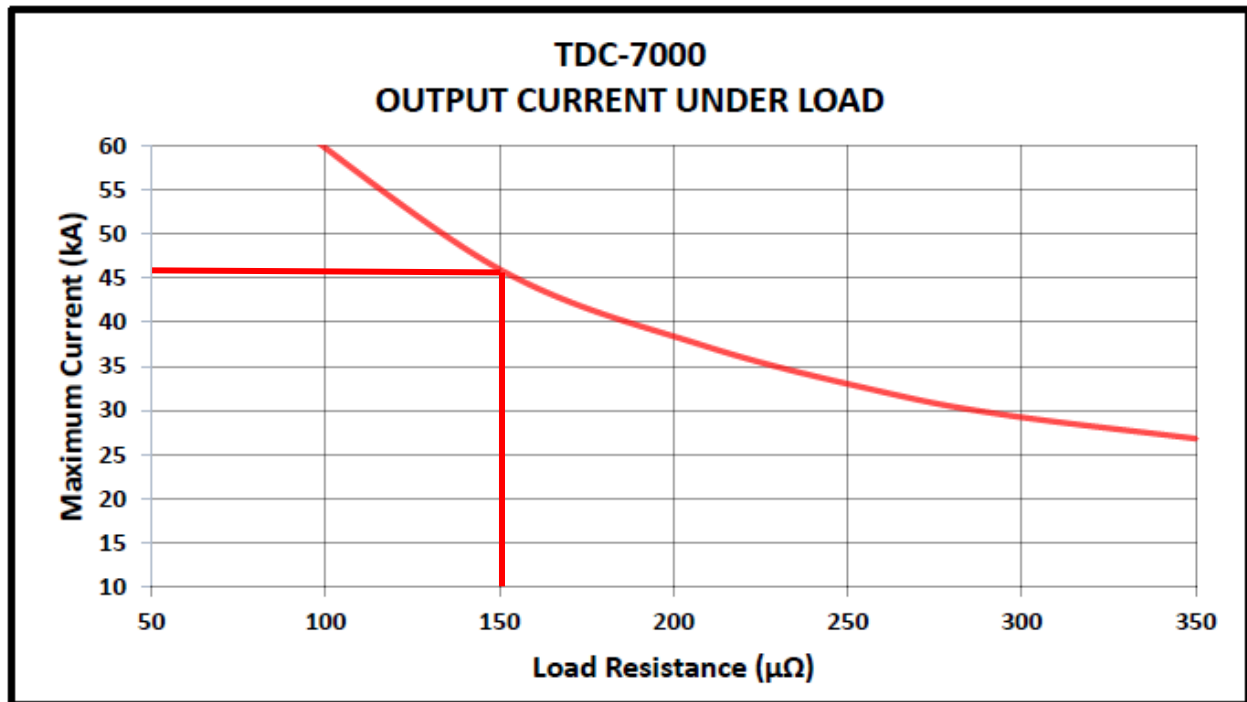
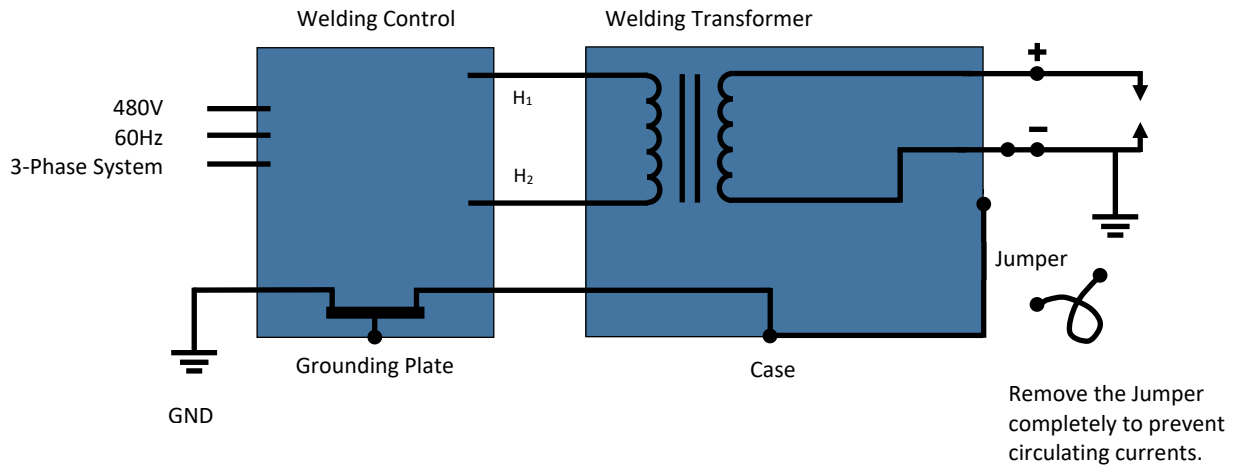

Figure 7: Secondary load curve example

## SECONDARY GROUNDING GUIDE

When looking at grounding, there are two main options: grounding the secondary directly or using a grounding reactor. See the figures below for wiring examples.



*Figure 8: AC Transformer Grounding the Secondary Loop*

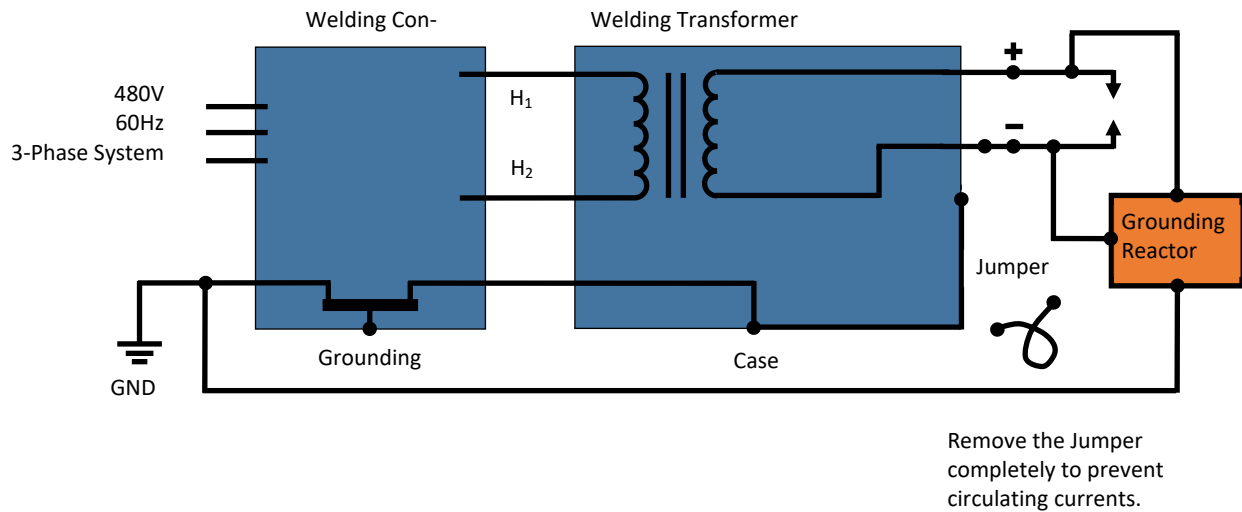

*Figure 9: AC Transformer Grounding Reactor*

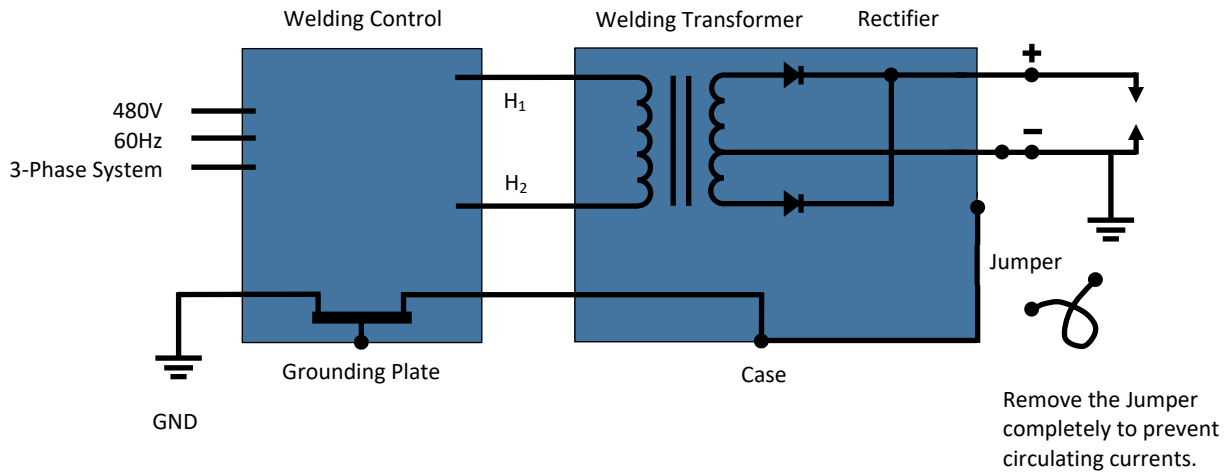

Figure 10: DC Transformer Grounding Secondary Loop

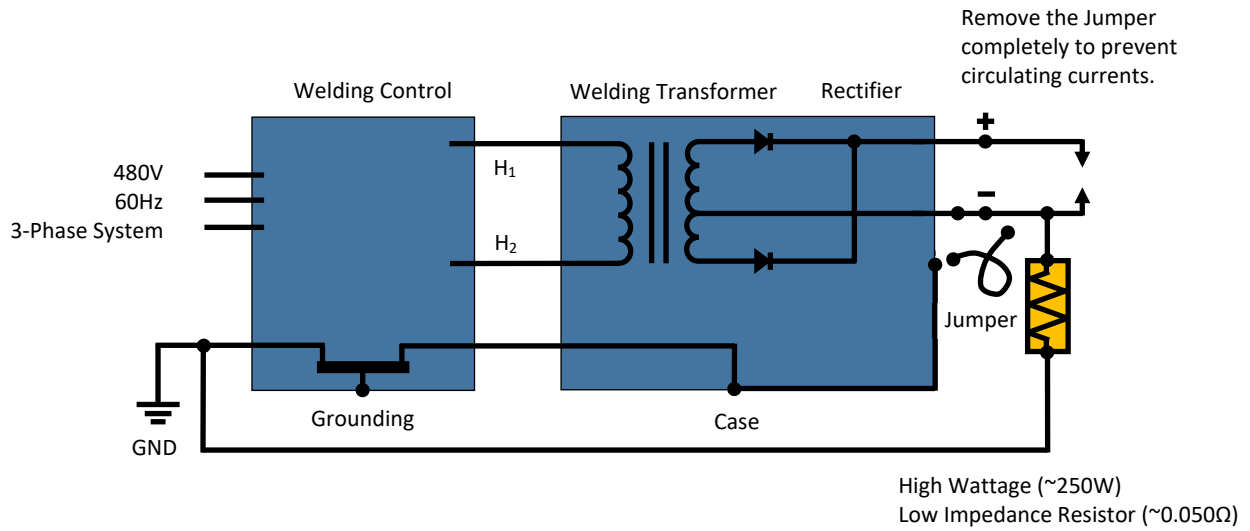

Figure 11: DC Transformer Grounding Resistor



## APPENDIX I: FURNACE ADDENDUM

---

### LOAD POWER RATING

All sizing requirements start with the end use requirement or Load. Electrical loads are loads which consume active electric power or "real" power. The load is defined at the point of use by the customer. For instance, in a furnace, a customer defines how many Watts of power will be required to heat the furnace to a specified temperature and designs heating elements to achieve that wattage value. The customer determines what Ohmic value they can design the heating elements to and the current that will be required to achieve that wattage value using the power calculation:

$$kW = \frac{I_{sec}^2 * R_{sec}}{1000}$$

Where k = kilo, W = Watts of power, I = Amperes of current flow, R = Ohms of resistance

And then voltage required at the load is defined by Ohm's law:

$$V = I * R$$

Where V = Volts of potential, I = Amperes of current flow, R = Ohms of resistance

#### **IMPORTANT:**

It is imperative to understand that all power utilized by a system is determined by the load. Unless a control is artificially limiting current flow, the load determines how much current is drawn. A transformer does not control or determine the power drawn. For example, a 10 kVA transformer is supplying 100 V to a 1 Ω load, by Ohm's law the load will draw 100 A. If the load decreases to 0.5 Ω then the load will draw 200A. The transformer will provide 200 A, but the internal design of the transformer will cause it to overheat, therefore the size of the transformer would have to be increased to 20kVA for that load requirement. The transformer could be increased to 40 kVA, but the load will still only draw 200A. In other words, the transformer does not determine the current draw. The rating of the transformer can be any size larger than the load requirement. For economical and space constraint reasons the transformer is sized based on the load with some minimal headroom allowance. It should be noted that parasitic losses in the transformer and the lines feeding the transformer and load can add resistance, capacitance, and inductance that affect the load current draw by creating additional resistance or impedance. A review of the parasitic losses is suggested to ensure proper operation. These parasitic losses need to be considered, but they do not negate the fact that the load defines the power draw.

Note: The National Electric Code (NEC) defines a general rating value that gives a maximum value for an overcurrent protection device. A standalone product may need overcurrent protection size per code defined maximum due to inrush current but does not have to be rated to the maximum value. A transformer as a component of a control system is limited by the control and an overcurrent protection device should be sized in accordance with the system requirements as opposed to the transformer rating. Because the transformer must be rated above the requirements of the load, the transformer requirements may be greater than that of the system. While overcurrent protection may be sized according to the transformer's capabilities, it must be sized based on the system requirements, as decided by the system manufacturer, as a minimum.

## AC TRANSFORMER POWER RATING

When sizing a transformer, the power capabilities are communicated using apparent power, measured in kVA or kilo-volt-ampere. When looking at a power triangle, the apparent power encompasses both the real and reactive power of a system. Apparent power is represented by the hypotenuse of the triangle.

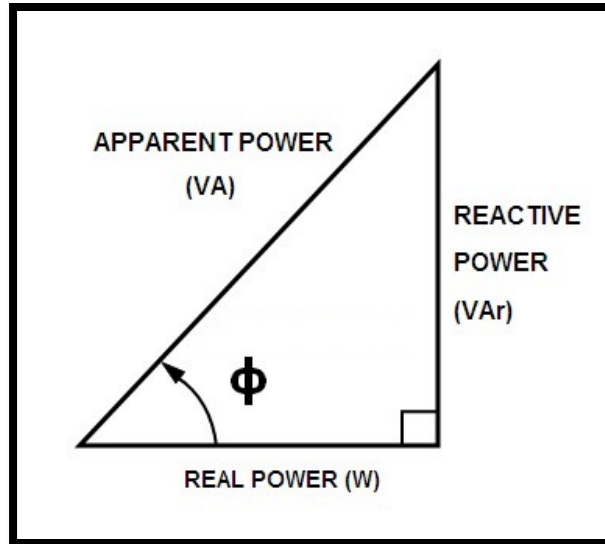

*Figure 12: Power Triangle*

To calculate the kVA of a transformer, use the equation below. Using basic trigonometry and the power factor, real and reactive power can be calculated.

$$kVA = \frac{I_{primary} * V_{primary}}{1000} \qquad kVA = \frac{I_{sec}^2 * Z_{sec}}{1000}$$

Where impedance, Z, is defined as the square root of the sum of the squares of resistance, inductance, and capacitance.

Product ratings are dependent on the duty cycle at which they are run. RoMan's furnace products are all rated based on a continuous duty cycle. This rating, in kVA, represents the maximum apparent power draw capabilities of the product.

Transformers are passive electrical components that respond to an input to produce an output. For example: assuming the turns ratio of the transformer is 25:1, it can be calculated that if 480V is used as a primary input that the theoretical secondary voltage will be 19.2 V, unloaded. Similarly, if the load on that same transformer is 5.48 mΩ then using Ohm's law, the theoretical secondary current can be calculated to be about 3504 A. Looking back on the primary side, the turns ratio is used to find that the primary current is about 140 A (3500 \* 1 / 25). Using the above equation, the continuous, theoretical kVA draw of this transformer is about 67 kVA. The actual values of a system are determined using the above calculations based on the full load voltage rating.

In the above situation, even though the transformer is using 67 kVA, the transformer rating can be anything above that, which is a function of the primary voltage and the secondary load. By adjusting these two values, the power used by the same transformer can be adjusted.

### 3 PHASE POWER

Three phase power used three AC phases offset by  $120^\circ$  to create a balanced power output that maximized the power output while minimizing the wiring needs. This creates a voltage wave as seen in figure 2.

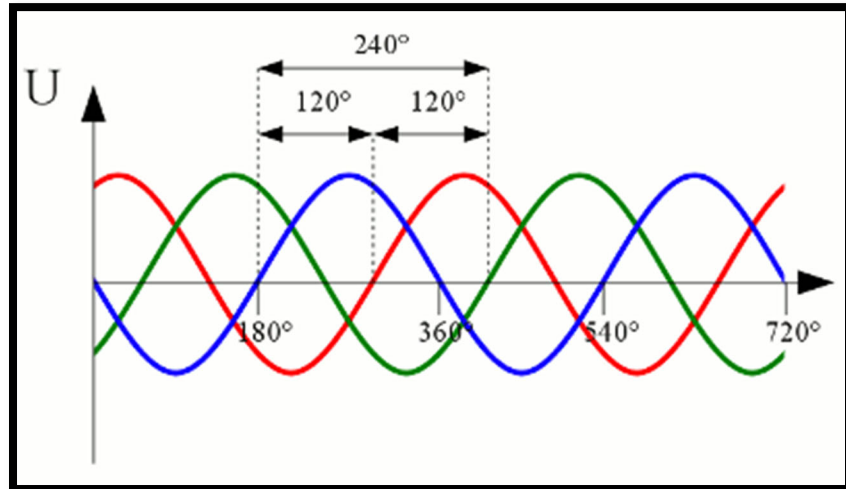

Figure 13: Three-Phase Voltage Curves

A basic three-phase circuit can either be in the form of a delta or a wye configuration. The delta configuration connects each of the three phases end-to-end to form an equilateral triangle with each line coming from each corner of the triangle. The wye configuration connects each of the three phases to a central neutral point, and each phase goes to its respective line.

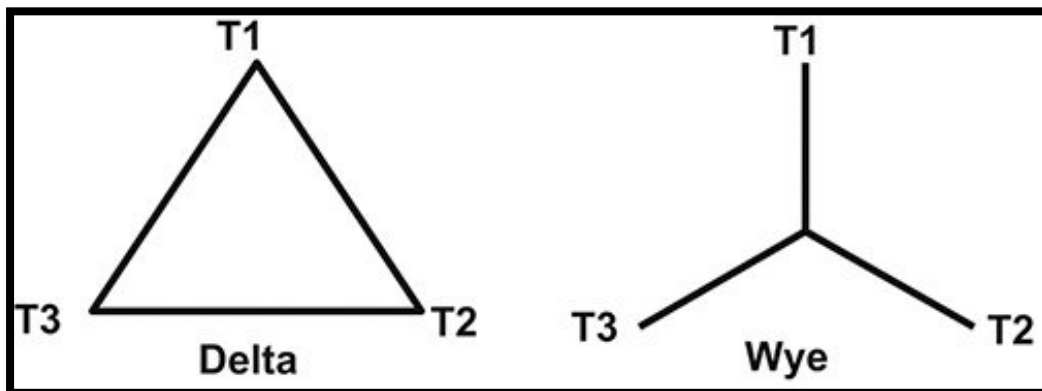

Figure 14: Three-Phase Connection Diagrams

For power generation and the primary of three-phase transformers, a delta configuration is used more often as it has inherent 3<sup>rd</sup> harmonic blocking ability. RoMan's three-phase transformers are made from three separate single-phase transformers in a delta configuration so that in the case that one leg of the system fails, the other two phases can still provide power to the remaining two legs. Additionally, in a Wye-to-Wye configuration, there is a greater possibility of unbalance. The advantage of a wye configuration is the ability to provide a neutral point single grounding location.

## IGBT CONTROL TECHNOLOGY

IGBT control technology converts a 3-phase AC input signal to a single-phase square wave output with a controllable voltage and frequency output. This output control is made possible by the circuit in figure 4.

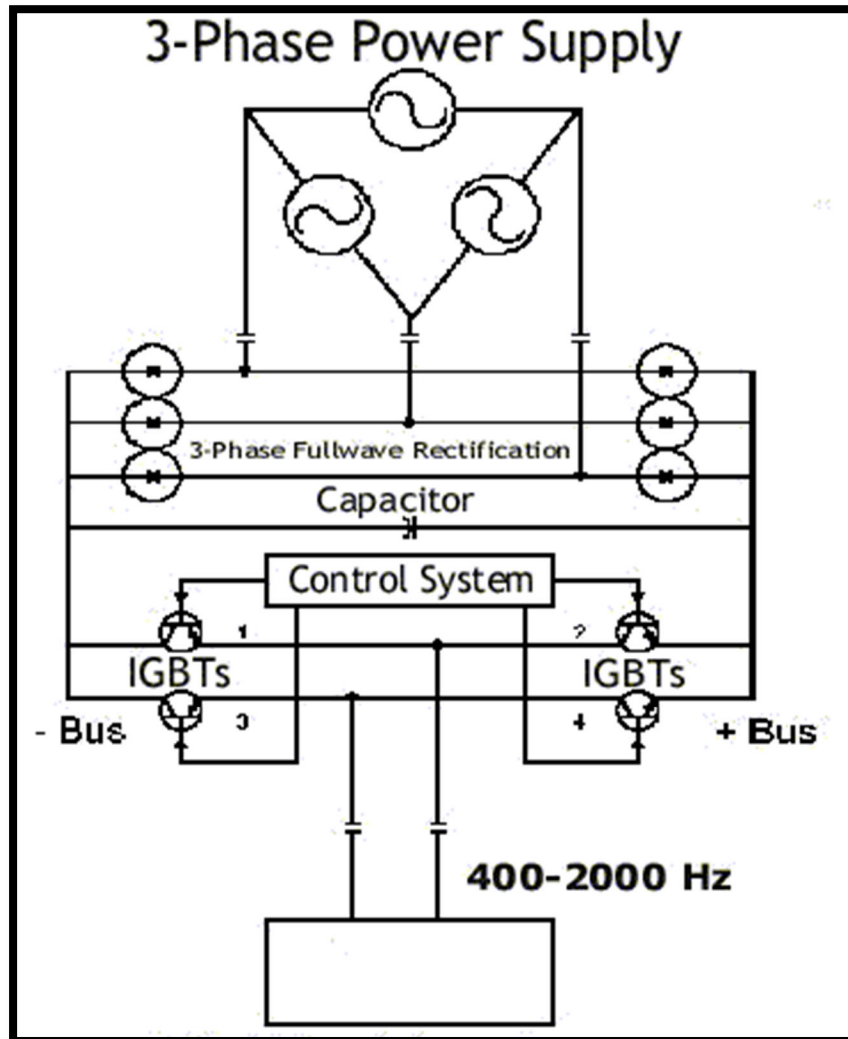

Figure 15: IGBT Circuit Diagram

The control system rectifies and filters the input to create a DC signal. The IGBTs then use a carrier frequency to create an AC square wave with a frequency dictated by the control's settings. IGBT controls are commonly used in Mid-Frequency Direct Current applications but benefits also extend to the resistive heating applications. Two of the greatest benefits of this type of system are a higher precision of control and the ability to create higher efficiency, higher power factor systems through improved design.

## APPENDIX J: MONITORING

### THERMAL MONITORING

Most product failures occur due to excessive heat. To ensure that the product does not overheat, thermocouple or thermal switches are used to provide the control with a feedback loop to ensure that the product does not overheat.

#### THERMOCOUPLES

Thermocouples use the phenomena known as the Seebeck effect or the thermoelectric effect. The thermoelectric effect uses the voltage produced by the temperature gradient across two dissimilar metals to track relative temperature. The point at which the two metals are attached together is called the "hot end," which is compared to the "cold end" at which the voltage is measured, see figure 5. To read an absolute temperature, a temperature reading must be taken at the "cold end" to use as an offset. The relative temperature can be looked up in a chart which is usually referenced to zero. The reference temperature is added to the temperature relative to zero to produce the absolute temperature.

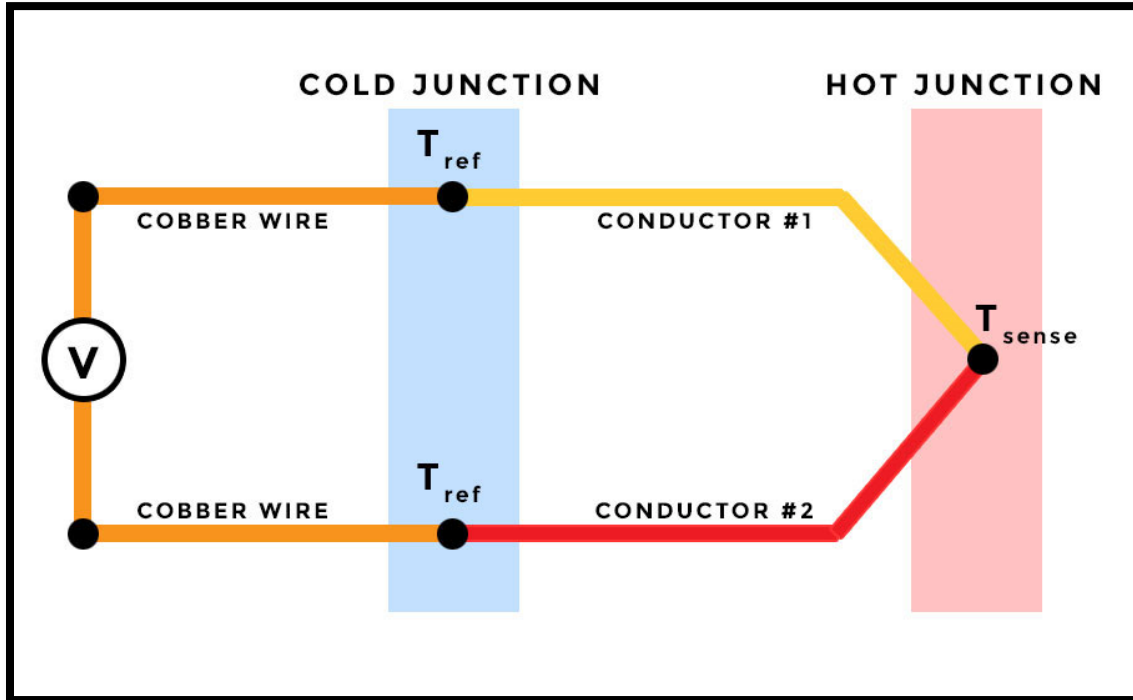

Figure 16: Thermocouple Diagram

When used in a product, thermocouples are used to allow temperature monitoring throughout the process. RoMan applies thermocouples at customer request to Primary and/or Secondary windings within the transformer. Depending on the type of transformer these can be used to monitor heat generated within the windings. At the customer's request, thermocouples can also be tied into the control system to be used as an input for an alarm. Thermocouples are not, however, approved for fail-safe protection, and using them as such would be at the customer's own risk. J type thermocouples are used on all RoMan Products unless specified by the customer.

## THERMAL SWITCHES

Thermal switches are mechanical circuit making or breaking switches that use the expansion properties of specially made bimetallic components that open or close a switch that is connected to a control or alarm circuit connection at a preset temperature. The two metals expand at different rates causing the bimetallic strip to bend and open the electrical connection, see figure 6.

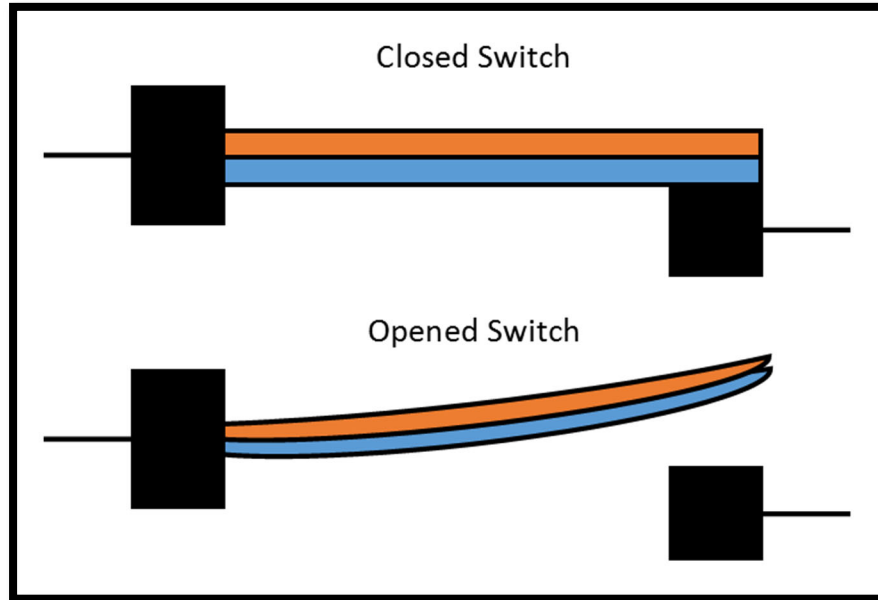

Figure 17: Normally Closed Thermal Cutoff Switch

RoMan provides normally closed thermal switches as a standard that operate at preset values based on our internal insulation design. These switches activate at temperatures to protect the insulation from insufficient cooling water flow and long-time overload. We do not apply alternate temperature ratings to thermal switches as we have values that are consistent with our class F-155C insulation system. The standard switches used by RoMan will be tripped at 85 °C on the secondary, and 120 °C on the primary. On special request, normally open thermal switches are available but may add cost and extend delivery time. Please note these thermal switches will **NOT** protect against an instantaneous heavy overload. They may also not prevent damage to the product in the event of a total loss of water since the increase in temperature may be too rapid to prevent insulation failure or damage from expanding steam.

## **FLOW MONITORING**

A precursor to overheating is typically a loss of or insufficient coolant flow. This can be monitored to ensure adequate cooling of the product.

### **FLOW SWITCHES/MONITORS**

RoMan recommends water flow switches/meters be applied to the outlets of the water manifolds of products. Monitoring the water output ensures that an accurate measurement of water that is passing through the product. These meters can notify instantly of water loss or degradation of flow due to corrosion in the cooling system. There are several types available. Visual flow indicators are good for periodic visual confirmation of flow and can indicate some reduction in flow based on the kinetic activity in the viewing bulbs. Flow switches will give an indication of if water flow is below a set minimum value. A flow meter will give an exact indication of how much water is flowing and provides the maximum protection value for the cooling system.

## TERMINAL LABELS

Below is a list of common abbreviations used on RoMan's products within terminal blocks or connection labeling.

<b>Label:</b>	<b>Description:</b>
<b>R.C.</b>	Rogowski Coil
<b>T/S</b>	Thermal Switch
<b>C/T</b>	Current Transformer
<b>SV</b>	Secondary Voltage
<b>TC#1+</b>	Thermocouple #1 Positive (+)
<b>TC#1-</b>	Thermocouple #1 Negative (-)
<b>XPP</b>	Center Tap

### NOTES

---

---

---

---

---

---

---

---

---

---

---

---